

AIR COOLING

Series BF

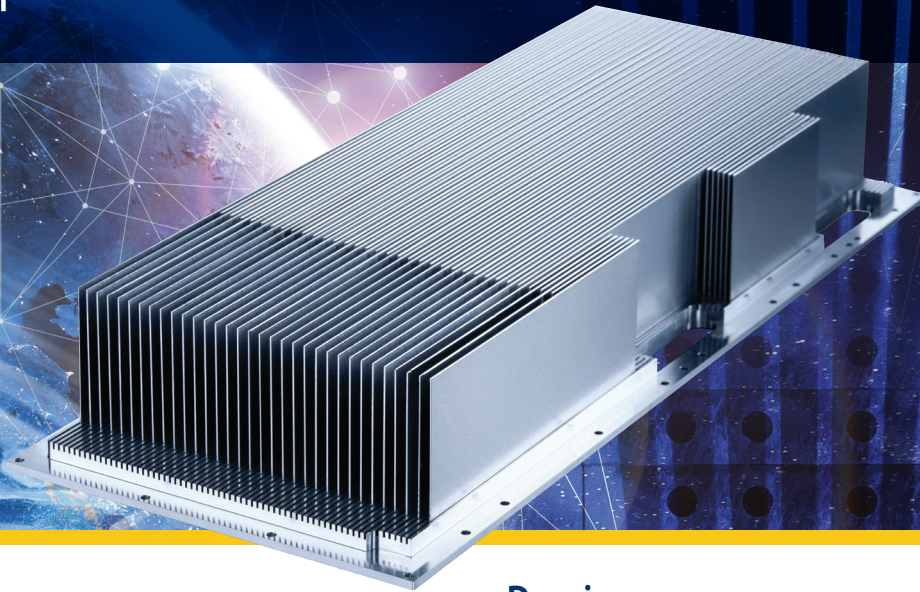

Application

Bonded Fin Heat Sink for efficient air cooling of IGBTs and resistors. DAU offers high performance customized solutions for all IGBT and resistor types available on the market.

General Characteristics

Heat sinks are produced by using an aluminium base section into separate fins are assembled. The joint between the base section and the fin is made by using a special, high density epoxy resin to guarantee optimal heat flow from the base plate to the fins. All types are available in any desired length and fin height.

Drawing

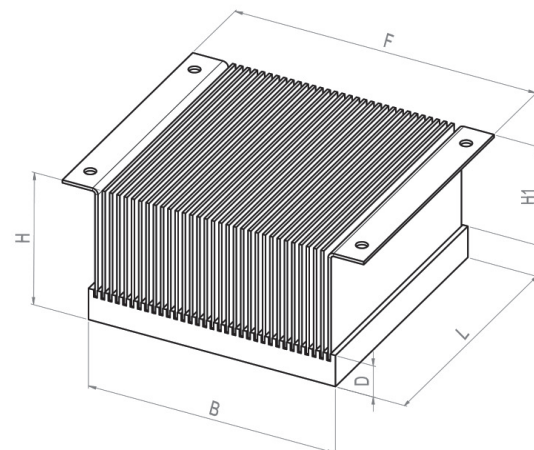
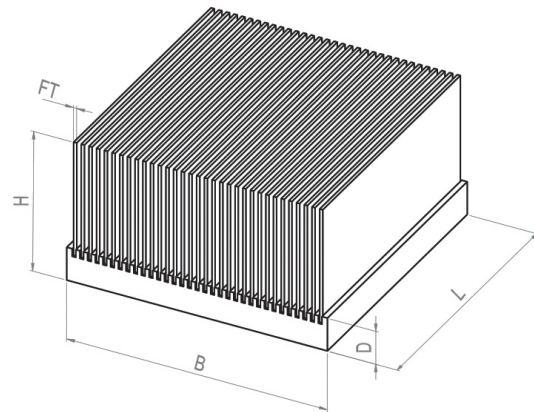

Type	Width B mm	Thickness D mm	Number of Fins	Fin Thickness FT mm	Length L mm	Height H mm
BF 51	50,8	9,0	16	0,8	50,8	50,8
BF 76	76,2	9,0	24	0,8	101,6	50,8
BF 78	87,0	9,0	25	0,8	101,6	50,8
BF 100	100,0	13,0	33	1,2	101,6	54,8
BF 102	101,6	9,0	33	0,8	101,6	50,8
BF 120	120,6	12,0	33	1,2	101,6	53,8
BF 120 T2	120,6	16,0	33	1,2	101,6	57,8
BF 121	121,4	8,5	34	0,8	101,6	50,3
BF 121 T2	121,4	12,0	23	1,2	101,6	53,8
BF 146	146,0	8,5	41	0,8	152,4	50,3
BF 151	151,4	10,5	30	1,2	152,4	52,3
BF 170	170,0	12,0	33	1,2	152,4	53,8
BF 170 T2	170,0	16,0	33	1,2	152,4	57,8
BF 176	176,0	15,5	54	0,8	152,4	57,3
BF 203	203,2	9,0	66	0,8	203,2	50,8
BF 223	223,0	16,0	43	1,2	203,2	57,8 84,0
BF 254	254,0	20,5	43	1,2	254,0	62,3 84,0
BF 277	276,6	20,5	47	1,2	254,0	62,3 84,0
BF 320	320,0	20,5	52	1,2	320,0	62,3 84,0
BF 340	340,0	16,0	66	1,2	340,0	57,8 84,0



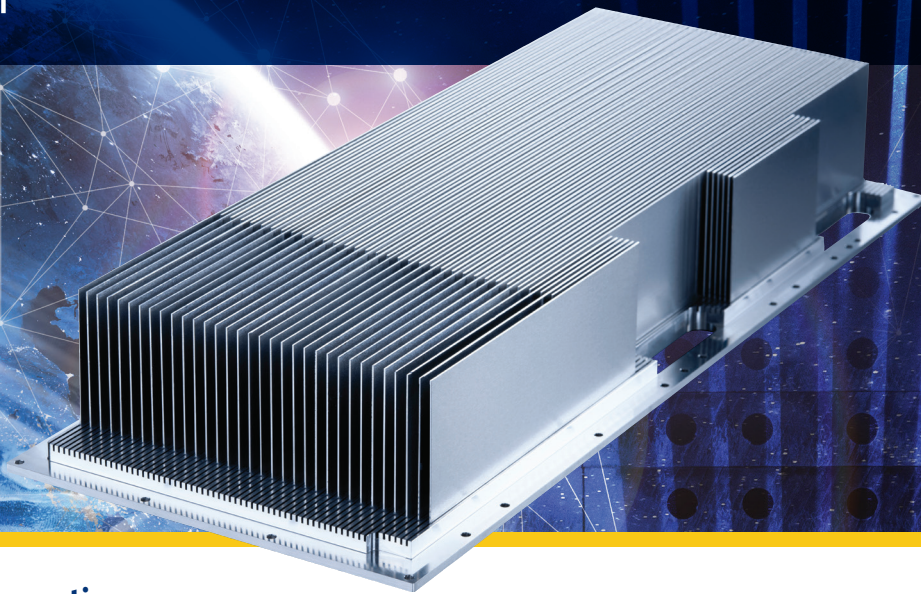

General informations

Modern high power semiconductors must be cooled efficiently to take advantage of their high current capabilities. Conventionally air cooled extruded aluminium heat sinks have been an accepted cooling method used since the beginning of the semiconductor age. Now, with increasingly higher power densities, the thermal performance demand for effective heatdissipation exceeds the limits achievable with conventional extruded heat sinks. To meet the increased performance demand DAU has designed a new generation of power heat sinks - HIGH POWER BONDED FIN HEATSINKS.

These heat sinks are produced by using an extruded aluminium base section into which separate fins are assembled. The joint between the extruded base section and the fin is made by using a special, high density epoxy developed by DAU together with a well-known producer of epoxy resin to guarantee optimal heat flow from the base plate to the fins.

The thermal conductivity of this material is extremely high in comparison to other epoxy-materials, and so enables the bonded fin heatsink to achieve a high thermal performance which exceeds all other assembly techniques.

Details for RTH Definition

Rth 60% means that heat source is 60% of heat sink base plate surface.

Rth 60% bedeutet, dass die Größe der Wärmequelle 60% der Grundfläche der Basisplatte beträgt.

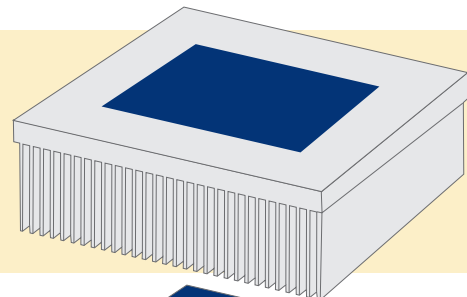

Details for RTH Definition

Rth 100% means that heat source is the same size as the heat sink base plate surface.

Rth 100% bedeutet, dass die Größe der Wärmequelle 100% der Grundfläche der Basisplatte beträgt.

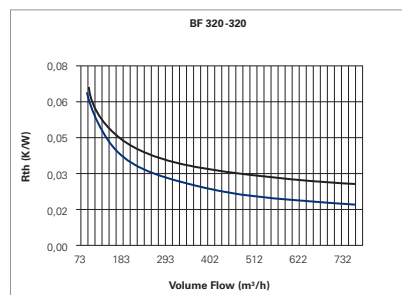
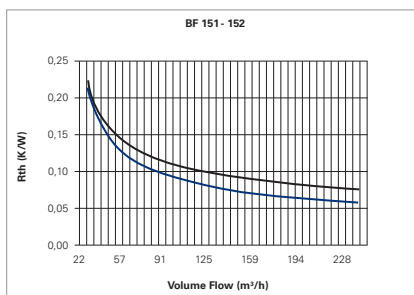
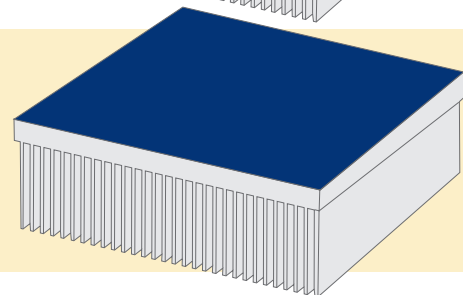

Description

blue line 100%
black line 60%

